

CRD5170 Multifunction Transducer, 3-Phase, 4-Wire



Heartbeat and
Communication
Indicators

Pre-calibrated with
Non-volatile
Memory

Current Input
up to 25 Aac

Three Phase and
Single Phase

Voltage Input
up to 300 Vac

RS485 Output

Din Rail or
Surface Mount

RS485
Terminals

RS232, DB-9
Connector



CRD485-232

RS485 to RS232 Converter
Connect PC to RS485 Bus

MEASURES:

- True RMS voltage
- True RMS current
- Power factor
- Active power (Bi-directional)
- Active energy (Bi-directional)
- Reactive power (Bi-directional)
- Reactive energy (Bi-directional)
- Frequency

APPLICATIONS:

- Sub-metering
- Motor loads
- Remote monitoring
- Automatic Control Systems
- Load Shedding

Part Numbers

MULTIFUNCTION DIGITAL TRANSDUCER:

- CRD5110 - □ - □ 1 Phase, Multifunction Transducer
 - CRD5150 - □ - □ 3 Phase, 3-Wire Multifunction Transducer
 - CRD5170 - □ - □ 3 Phase, 4-Wire Multifunction Transducer
- | | |
|---|---|
| <ul style="list-style-type: none"> 150 - 0-150 Vac 300 - 0-300 Vac <p style="text-align: center; margin-left: 40px;">other ranges available</p> | <ul style="list-style-type: none"> 1 - 0-1 Aac 5 - 0-5 Aac 15 - 0-15 Aac 25 - 0-25 Aac <p style="text-align: center; margin-left: 40px;">other ranges available</p> |
|---|---|

DIGITAL CURRENT TRANSDUCER:

- CRD4110 - □ 1 Element Current Transducer
 - CRD4150 - □ 2 Element Current Transducer
 - CRD4170 - □ 3 Element Current Transducer
- | | | |
|----|----------|------------------------|
| 1 | 0-1 Aac | |
| 5 | 0-5 Aac | |
| 15 | 0-15 Aac | |
| 25 | 0-25 Aac | other ranges available |

NOTE: Ranges may be extended by using external Current and Voltage Transformers.

See page 4 for connection methods and request CR Magnetics Current and Voltage Transformer catalogs.

DIGITAL VOLTAGE TRANSDUCER:

- CRD4510 - □ 1 Element Voltage Transducer
 - CRD4550 - □ 2 Element Voltage Transducer
 - CRD4570 - □ 3 Element Voltage Transducer
- | | | |
|-----|-----------|------------------------|
| 150 | 0-150 Vac | |
| 300 | 0-300 Vac | other ranges available |

ACCESSORIES:

- CRD485-232 Non-isolated RS485 to RS232 Converter
- CRPS24VDC-120 120 Vac to 24 Vdc Power Supply
- CRPS24VDC-240 240 Vac to 24 Vdc Power Supply

Dimensions

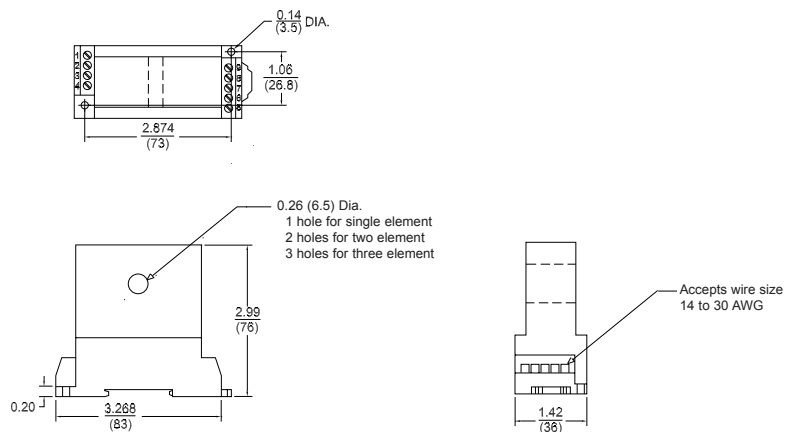

inch (mm)

Specifications

| | | |
|--------------------------------------|--|-----------------|
| Basic Accuracy : | ± 0.5 | % Full Scale |
| Calibrated Range : | 5 to 100 | % of Full Scale |
| Input Current Ranges : | 0-1, 0-5, 0-15, 0-25 | .Aac |
| Input Voltage Ranges : | 0-150 & 0-300 | .Vac |
| Measurement Frequency : | 45 to 65 | .Hz |
| Continuous Over Current : | 10 times | .Full Scale |
| Continuous Over Voltage : | 2 times | .Full Scale |
| | | |
| Isolation Voltage : | 2500 | .Vdc |
| Supply Voltage ₁ : | Single sided, +24 ± 5% | .Vdc |
| Supply Power : | less than 250 | .mW |
| Output ESD protection : | ± 15 | .KV |
| Auxiliary Output voltage : | 5 ± 5% | .Vdc |
| Auxiliary Output current : | 20 | .ma max. |
| | | |
| Output Resolution : | 16 | .bit |
| Transducer fanout on common bus : | 64 | .max. |
| Baud Rate ₂ : | 1200, 2400, 4800, 9600, 19.2 K | .bps |
| A/D Conversion Type : | 4th order Delta Sigma | |
| Device Address ₂ : | .00 to FF | |
| Data Format : | .ASCII | |
| | | |
| Operating Temperature ₃ : | .0 to +50 | .°C |
| Storage Conditions ₃ : | -20 to +80 | .°C |
| Mounting : | 35 mm Din rail or surface mount | |
| Status Indicators : | Red Heartbeat LED and Green Communication LED | |
| Terminals : | data +, data -, +5 Vdc out, Ground, + 24 Vdc in | |

₁ 0.4 % max. ripple Vpp

₂ Factory default settings: address 01, baud rate 9600, no parity, no flow control, 1 stop bit

₃ RH 5% to 95%, non-condensing

RS485 to RS232 Converter Accessory

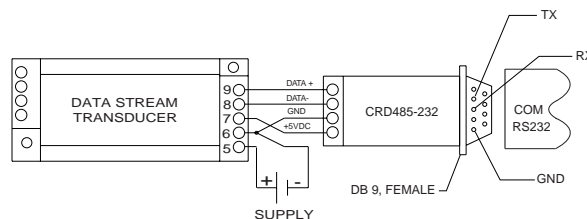

Extending Measurement Range with Current and Voltage Transformers

The range of any Data Stream Transducer can be extended with the use of CR Magnetics' ANSI grade current transformers and voltage transformers. In these applications, current transformers step down higher currents into standard 5 Amp AC current inputs, and voltage transformers step down higher voltages into standard 120 VAC inputs. This allows the designer to measure any application with a single transducer.

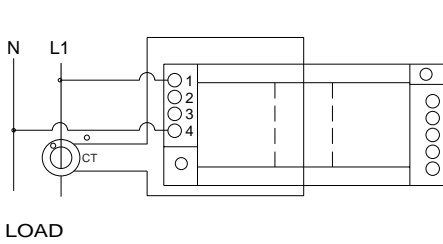

Single Phase

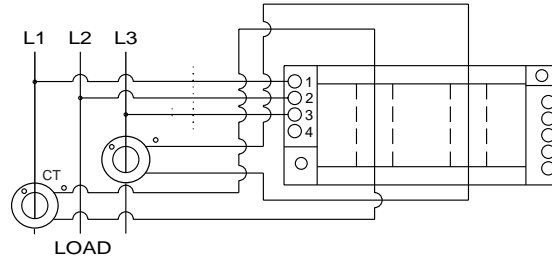

3 Phase 3-Wire

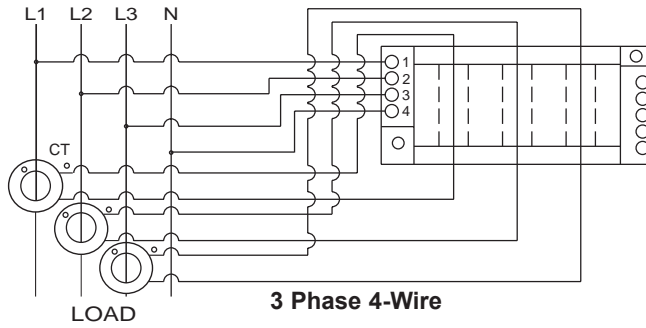

3 Phase 4-Wire

CURRENT TRANSFORMERS

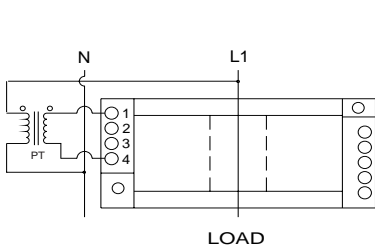

Single Phase

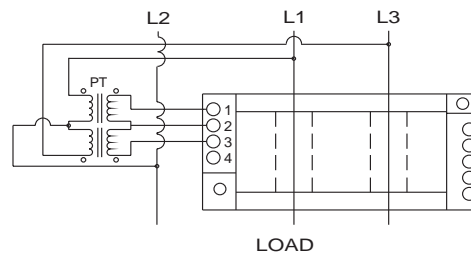

3 Phase 3-Wire

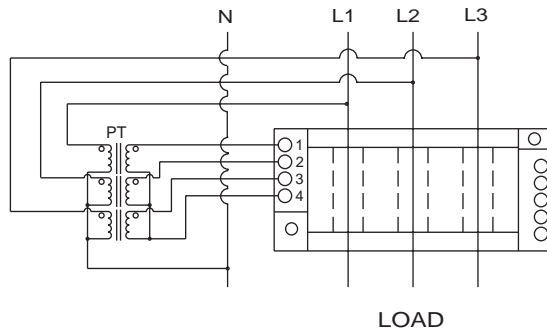

3 Phase 4-Wire

VOLTAGE TRANSFORMERS

Connection Drawings

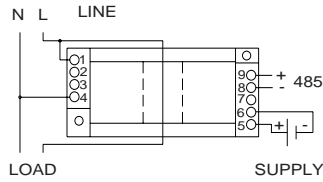

CRD5110
MULTIFUNCTION TRANSDUCER

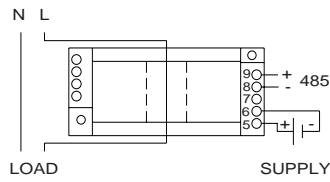

CRD4110
CURRENT TRANSDUCER

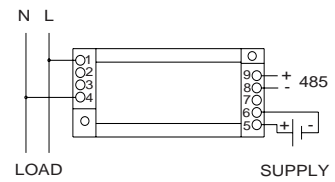

CRD4510
VOLTAGE TRANSDUCER

SINGLE PHASE, 2-WIRE

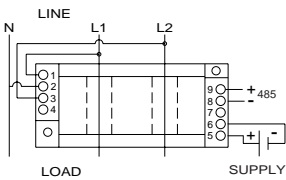

CRD5150
MULTIFUNCTION TRANSDUCER

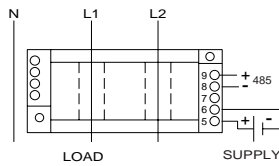

CRD4150
CURRENT TRANSDUCER

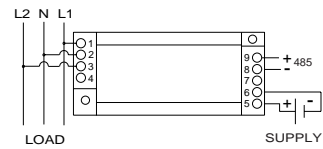

CRD4550
VOLTAGE TRANSDUCER

SINGLE PHASE, 3-WIRE

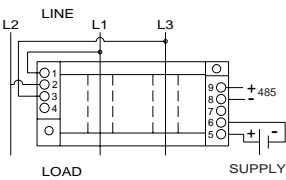

CRD5150
MULTIFUNCTION TRANSDUCER

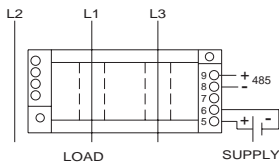

CRD4150
CURRENT TRANSDUCER

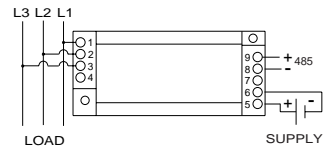

CRD4550
VOLTAGE TRANSDUCER

THREE PHASE, 3-WIRE

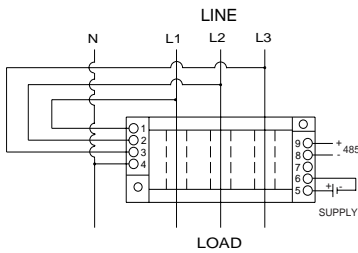

CRD5170
MULTIFUNCTION TRANSDUCER

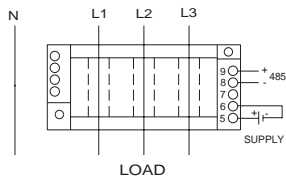

CRD4170
CURRENT TRANSDUCER

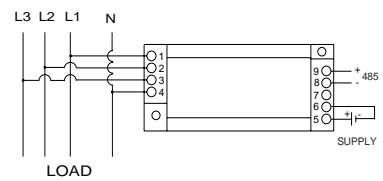

CRD4570
VOLTAGE TRANSDUCER

THREE PHASE, 4-WIRE

NOTE: LINE and LOAD connections as shown on the multifunction transducers will provide a positive (+) power and energy output. LINE and LOAD connections reversed on the multifunction transducers will provide a negative (-) power and energy output.

Programming

Programming of the CR Magnetics DATA STREAM Series is straight forward and easily implemented via user programs or The DATA STREAM Software. The programming language is ASCII based and consists of Commands and Return data.

| List of Common Commands | | | | |
|--------------------------------|-----------------|-------------|------------|---------------------------------|
| Command | Preamble | Addr | Dir | Data |
| Read Transducer Name | \$ | 00 to FF | M | N/A |
| Read All Data | # | 00 to FF | A | N/A |
| Read Energy Totalizer | # | 00 to FF | W | N/A |
| Read Transducer Configuration | \$ | 00 to FF | 2 | N/A |
| Set Transducer Configuration | % | 00 to FF | N/A | New Addr, Input Range, New Baud |
| Clear Energy Totalizer | & | 00 to FF | N/A | Totalizer Period Number |

Command Structure

Each command sent to the DATA STREAM has the following structure:

Preamble Addr [Dir] [Data] <cr>

Preamble A single ASCII character which designates type of command.

Addr 2 ASCII characters which selects the address of the transducer.

[Dir] A single ASCII character directive which qualifies the command, not used on all commands.

[Data] A set of ASCII characters required by certain command functions.

EOL A carriage return <cr> must be placed as an end of line character.

Transducer Wrong Response: ?
Addr (00 to FF)
<cr>

Example: Given a CRD5110, programmed with a Voltage range of 500VAC RMS, and a Current range of 5 AAC RMS, Address 1B.
Input Voltage =300 VAC RMS,
Input Current = 4 AAC RMS,
Power Factor = 1.000 (Pure resistive)
Frequency of 50 Hz.

Send #1BA<cr>
Receive >+0.6000+0.8000+0.4800+0.0000+1.000050.000<cr>

All signed data is returned as a percent of Full Scale. Thus the formula:

$$\text{Value} = \text{Data}(\%) \times \text{Full Scale}$$

Will give the actual value of the parameter.

For this example:
Voltage = +0.6000 X 500 = 300 VAC RMS
Current = +0.8000 X 5 = 4 AAC RMS
Real Power = +0.4800 X 500 X 5 = 1200 Watts
VARs = +0.0000 X 500 X 5 = 0.0000 Vars
Power Factor = +1.0000 X 100% = 100% PF (purely resistive)

The Frequency Value is the Actual Data:
Frequency = 50.000 Hertz

NOTE: Multifunction units will return Voltage, Current, Power, Vars, Power Factor, and Frequency. Single function units will return only the single function. For Multiphase units, the Voltage and Current Data will be returned in the following order:

3 Phase 3-Wire

Voltage_{L1-L2}, Current_{L1}, Voltage_{L3-L2}, Current_{L3},
Power, Vars, Power Factor, Frequency

3 Phase 4-wire

Voltage_{L1-N}, Current_{L1}, Voltage_{L2-N}, Current_{L2}, Voltage_{L3-N},
Current_{L3}, Power, Vars, Power Factor, Frequency.

Read Transducer Name Command

Preamble \$
Addr 00 to FF
Dir M
Data not used
EOL <cr>

Transducer Correct Response: !
Addr (00 to FF)
Name
<cr>

Transducer Wrong Response: ?
Addr (00 to FF)
<cr>

Example: Send \$0AM<cr>
Receive !0ACRD5110-120-5<cr>

In this case, a CRD5110 Single Phase Multifunction Transducer with a range of 120 Volts and 5 amps is programmed with the address 0A, and returns its last 4 digits to the system.

Read All Data Command

Preamble #
Addr 00 to FF
Dir A
Data not used
EOL <cr>

Transducer Correct Response:
Voltage % (+X.XXXX)
Current % (+X.XXXX)
Power % (+/-X.XXXX)
VARs % (+/-X.XXXX)
Power Factor % (+/-X.XXXX)
Frequency (XX.XXX)
<cr>

Programming (continued)

Read Energy Totalizer Command

Preamble #
Addr 00 to FF
Dir W
Data not used
EOL <cr>

Transducer Correct Response: >
 Period Counter (00 to FF)
 KWHr Data (+/-XXXXXX)
 KVHr Data (+/-XXXXXX)
 Checksum (XX)
 <cr>

Transducer Wrong Response: ?
 Addr (00 to FF)
 <cr>

Description of Totalizer Function

The energy totalizer function is a method by which the total amount of energy in KWHrs and KVARHrs used over a period of time can be measured. A data location within the program keeps a running total of the amount of energy used. This total starts from zero and begins totalizing the instant power is turned on to the transducer.

Totalizer data is outputted when the Read Energy Totalizer Command is sent to the transducer. At this point, the transducer outputs the amount of energy totaled since the last clear or restart. A counter called the time period counter, keeps track of the time period in which the data is valid. At turn on, the period counter is set to zero. The counter increments when the totalizer data is cleared. This counter turns back to zero after 255 counts (FF).

It is important to know that the output data represents the amount of energy used since the last clear or restart. This method makes it very useful for total energy used calculations.

A Clear Totalizer Command function is also provided to reset the totalizer as needed.

The largest period of totalizer data is 1,553.5 Hours with the full scale voltage and current being input to the device. Longer periods are possible with lower input voltages and currents.

The data output has gain and function factors that must be included when calculating actual KWHr/KVARHr. The formula is:

Energy = Data Read X Volt Range X Current Range / 3600000

Units are KWHrs and KVARHrs depending on data read.

Please note: Unlike other data read from the transducer, the energy data is transmitted as the ASCII representation of the HEX value. Hence, when the data would return as ASCII "FF", this is equivalent to the decimal value 255.

Checksum data is provided as a verifier of correct data communication. The Checksum data is generated by totaling the sum of all byte by byte data, in HEX, sent from the transducer after the Read Energy Totalizer Command is accepted, then taking this HEX value and performing a logical AND with the value FFH, and outputting it. The data is an ASCII representation of the HEX value.

Example: Given a CRD5110-300-5, programmed with a Voltage range 500VAC RMS, and a Current range of 5 AAC RMS, and Address 1B. Input Voltage =300 VAC RMS, Input current = 4 AAC RMS, Power Factor = 1.000 (Pure resistive) and a frequency of 50 Hz. Energy data has not been requested since turn on of the part. The command is sent after the part has been running one hour.

Send #1BW<cr>
Receive >00+0006C0+0000001E<cr>

Time Period = 00H = 0 Decimal
 KwHr Data = +0006C0H = 1,728 Decimal
 KwHr Actual = 1,728 X 500 X 5 / 3600000 = 1.2 KwHrs
 KVARHr Data = +0000000H = 0 Decimal
 KVARHrs Actual = 0 KVARHrs
 Checksum = 1EH

Doing the Check on the Checksum:

3EH+31H+2BH+30H+30H+30H+36H+43H+30H+2BH+30H+30H+30H+30H+30H = 31EH AND FFH = 1EH

Read Transducer Baud Rate Configuration Command

Preamble \$
Addr 00 to FF
Dir 2
Data not used
EOL <cr>

Transducer Correct Response: !
 Addr (00 to FF)
 Input Range (Always 00)
 Baud Rate Code (See Below)
 Data Format (Always 01)
 <cr>

Transducer Wrong Response: ?
 Addr (00 to FF)
 <cr>

Example: Send \$0A2<cr>
Receive !0A000601<cr>

In this case, a CRD5110 Multifunction Transducer is programmed with the Address 0A. Reading the configuration returns 0A for the address, 00 for the Input Range (fixed), 06 for 9600 bps Baud rate, and 01 for no check sum on standard data (Data Format is fixed).

Baud Rate Codes are as follows:

- 03 = 1200 bps
- 04 = 2400 bps
- 05 = 4800 bps
- 06 = 9600 bps (Default)
- 07 = 19200 bps

Programming

Set Transducer Address and Baud Rate Configuration Command

Preamble %
Addr 00 to FF
Dir not used
Data New Addr - 00 to FF
 Input Range - Always Set To 00
 New Baud Rate - 03 to 07
 Data Format - Always Set to 01
EOL <cr>

Transducer Correct Response: !
 New Addr (00 to FF)
 <cr>

Transducer Wrong Response: ?
 Addr (00 to FF)
 <cr>

Example: Send %0A0B000701<cr>
Receive !0B<cr>

In this case, a CRD5110 Multifunction transducer is programmed with the address 0A. The command changes the address to 0B, and sets the baud rate to 19,200 bps.

Clear Energy Totalizer Command

Preamble &
Addr 00 to FF
Dir not used
Data Time Period Count
EOL <cr>

Transducer Correct Response: !
 Addr (00 to FF)
 <cr>

Transducer Wrong Response: ?
 Addr (00 to FF)
 <cr>

Description of Clear Totalizer Function

The Clear Energy Totalizer Command is a method by which the internal energy totalizer can be reset to zero. The programmer simply addresses the transducer with the appropriate address, and also sends the correct time period number which will then clear the totalizer to zero.

The correct time period number is the value that was received with the last Read Totalizer Data Command. An incorrect period number will result in a command error, and the totalizer will not be cleared. Upon proper totalizer clear, the Time Period Counter will be increased by 1.

Should an invalid Clear Totalizer Command be refused (because of an incorrect address or an incorrect Time Period Number), the totalizer will not be cleared, energy data will continue to be totalized to the sum, and the Time Period Counter will not be incremented.

Example 1: A CRD5110 with Address 0A needs to have its totalizer cleared. The totalizer data has been cleared 3 previous times.

Send: &0A04<cr>
Receive: ?0A<cr>

In this example the CRD5110 received an incorrect order to clear the totalizer. The totalizer had been cleared 3 times and increased by 1. The current time period is 3

Example 2:

Send: &0A03<cr>
Receive: !0A<cr>

This command was sent properly, as the correct time period number was sent. Note that the Time Period Counter has been increased by 1, so the next Read Totalizer Command will give a time period number of 4.

Reset to Factory Defaults Command

As an aid to system startup, a Reset to Factory Defaults Command is provided. Since this command resets the transducer to Address 01 and Baud rate 9600 bps, no address is needed to run the command.

NOTE: THIS COMMAND CANNOT BE USED ON NETWORKED TRANSDUCERS. ALL TRANSDUCERS ON THE NETWORK WILL BE RESET, AND THE RESULTING RETURN INFO WILL CAUSE NUMEROUS BUS CONFLICTS. THIS IS FOR ONE-TO-ONE CONFIGURATIONS ONLY!!!

Example: Send: @CEAFW<cr>
Receive: ☺♠RSOK<cr>